

ALL DESIGN, OPERATIVE AND PROCESS DATA PERTAINING TO THE ARTICLE SHOWN ON THIS SHEET IS THE PROPERTY OF POLYPHASER CORPORATION. THE INFORMATION IS NOT TO BE COPIED, REPRODUCED, REVEALED TO OR APPROPRIATED BY OTHERS WITHOUT THE EXPRESS WRITTEN CONSENT OF POLYPHASER CORPORATION.

REVISIONS

REV LTR	DATE	ENG	MKTG	Q.A.
C	12/08/04 SH	KCB	SD	LJ

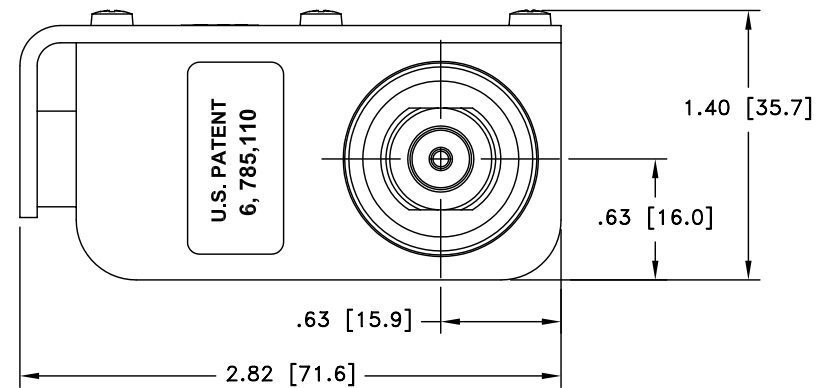
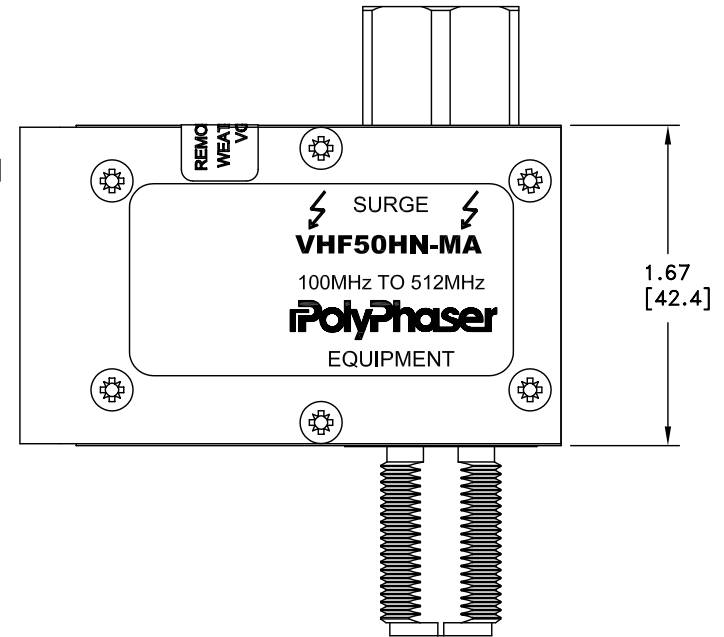
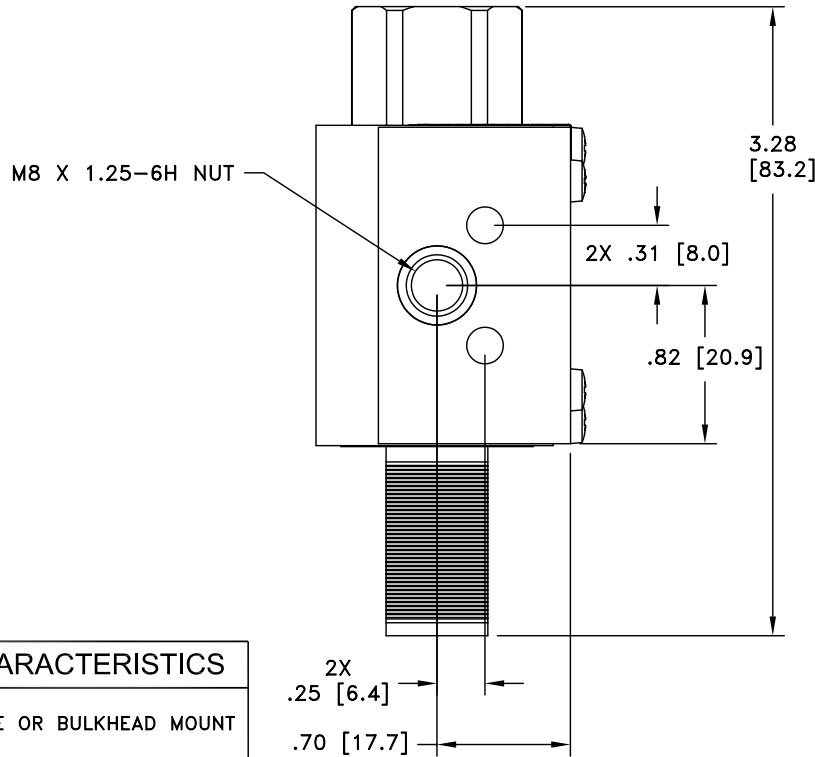

MAXIMUM CHARACTERISTICS

APPLICATION:
 WEATHERIZED, FLANGE OR BULKHEAD MOUNT
 FREQUENCY RANGE:
 100MHz TO 512MHz
 VSWR:
 ≤1.1:1 OVER FREQUENCY RANGE
 INSERTION LOSS:
 ≤0.1dB OVER FREQUENCY RANGE
 POWER:
 750W RMS AVERAGE
 MAX. SURGE:
 20kA IEC 61000-4-5 8/20μs WAVEFORM
 THROUGHPUT ENERGY:
 ≤500nJ FOR 3kA, 8/20μs WAVEFORM
 RELATIVE HUMIDITY:
 TO 95%
 ENVIRONMENTAL:
 MEETS IEC 60529 IP67
 MEETS BELLCORE #TA-NWT-000487
 PROCEDURE 4.11, WIND DRIVEN (120MPH)
 RAIN INTRUSION TEST.
 TEMPERATURE:
 -50°C TO +85°C STORAGE/OPERATING

CUSTOMER APPROVAL: _____ DATE: _____

ALL DIMENSIONS SHOWN ABOVE ARE FOR REFERENCE ONLY.

DRAFTER S. HALL	DATE 06/11/03	 P.O. BOX 9000 MINDEN, NV 89423 TEL: 775-782-2511 FAX: 775-782-4476 DWG NO/PART NO/DESCRIPTION VHF50HN-MA CUSTOMER PRINT	
MECH ENGINEER R. DUNNING	DATE 06/27/03		
ELEC ENGINEER N. TOPCU	DATE 06/26/03		
MARKETING S. DOTTER	DATE 06/27/03		
QUALITY DEPT L. JACQUES	DATE 06/26/03		
CAGE CODE 61114	FILE NAME -C1	SCALE 1/1	SHEET 1 OF 1